

Polymorphism



Tiziana Ligorio
Hunter College of The City University of New York

Today's Plan



What have we done so far

Inheritance Recap

Polymorphism

What have we done so far

- OOP
 - Inheritance
- Algorithm Analysis
- ADT & Templates
 - ArrayBag
 - Pointers and dynamic memory allocation
 - LinkedBag
 - LinkedList
 - DoublyLinkedList
 - Exception handling
- OOP
 - Polymorphism (TODAY)

Inheritance Recap

Basic Inheritance

```
class Printer
{
public:
    //Constructor, destructor

    void setPaperSize(const int size);
    void setOrientation(const string& orientation);
    void changeCartridge();
    void printDocument(const string& document);
private:
    // stuff here
}; //end Printer

class BatchPrinter: public Printer // inherit from printer
{
public:
    //Constructor, destructor
    void addDocument(const string& document);
    void printAllDocuments();
private:
    vector<string> documents; //Document queue
}; //end BatchPrinter
```

```
class GraphicsPrinter: public Printer // inherit from printer
{
public:
    //Constructor, destructor
    void changeCartridge();
    void printDocument(const Picture& picture);

private:
    //stuff here
}; //end GraphicsPrinter
```

Basic Inheritance

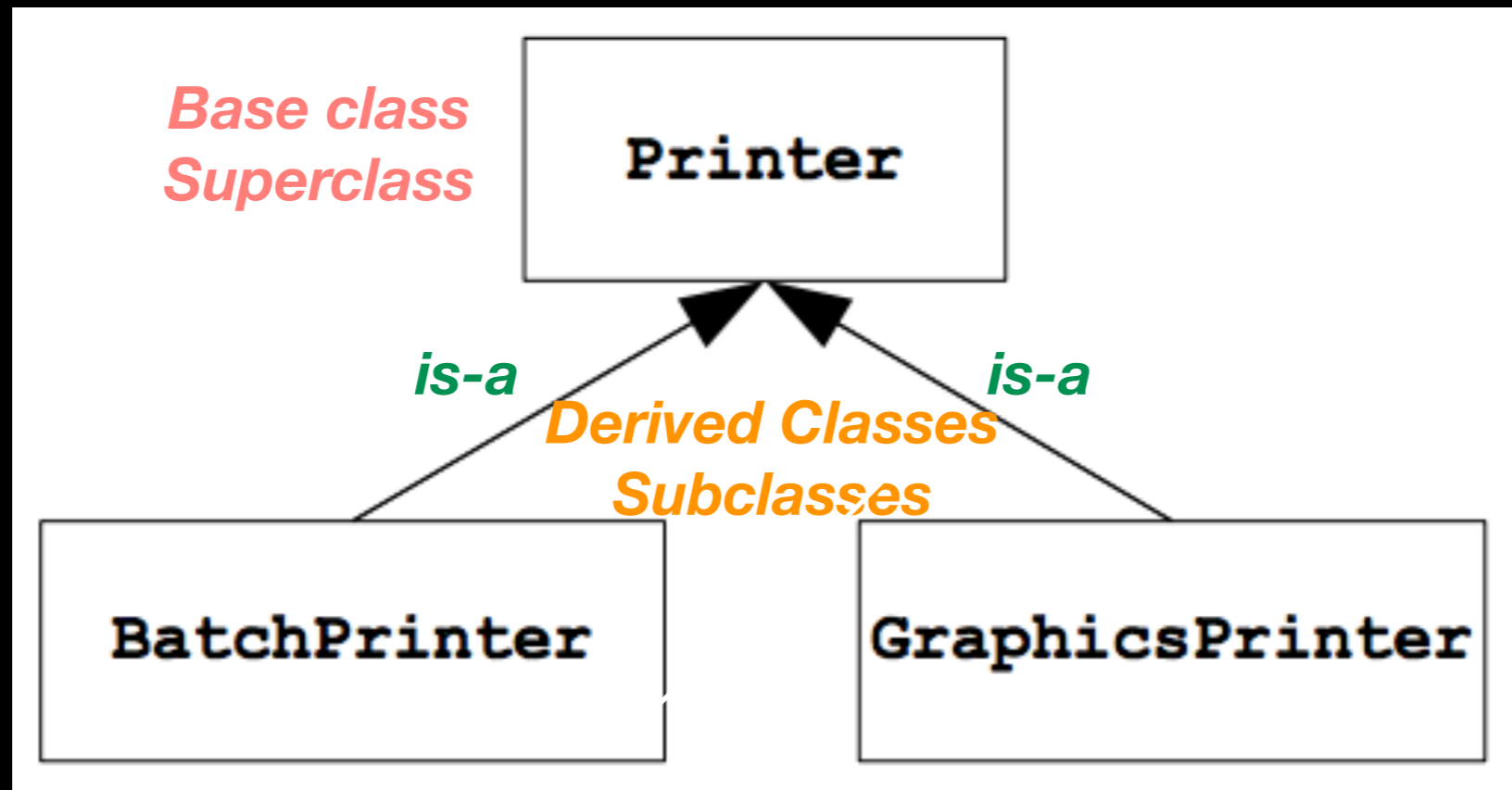

```
void initializePrinter(Printer& p)
{
    //some initialization function
}
```

```
BatchPrinter batch;
initializePrinter(batch); //legal because batch is-a printer
```

Think of argument types as specifying **minimum requirements**

Problem

```
class BatchPrinter: public Printer // inherit from printer
{
public:
    //Constructor, destructor
    void addDocument(const string& document);
    void printAllDocuments();
private:
    vector<string> documents; //Document queue
}; //end BatchPrinter
```

Can't store different types of documents in printer queue

We would like to print all kinds of documents not just text documents should be able to store different types of documents

Generalized Document

Whatever the type of document, a printer ultimately prints a grid of pixels

Generalized Document should know how to convert itself into a printable format

We want Document to be an *interface* => not concerned with implementation details

printAllDocuments()

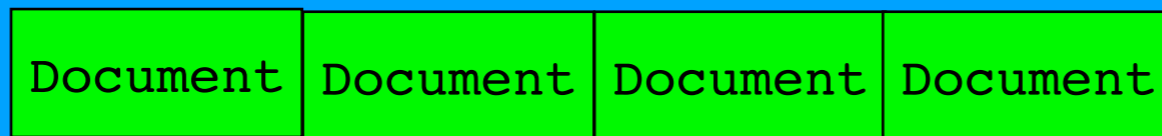

Document::convertToPixelFormat()
printPixelFormat()

Polymorphism

```
class BatchPrinter: public Printer // inherit from printer
{
public:
    //Constructor, destructor
    void addDocument(const Document* document);
    void printAllDocuments();
private:
    vector<Document*> documents; //Document queue
}; //end BatchPrinter
```

Abstract Class!

```
class Document
{
public:
    //Constructor, destructor
    virtual void convertToPixelArray() const = 0;
    virtual int getPriority() const = 0;

private:
    //stuff here
}; //end Document
```

This function has no implementation**



I'll explain this next

**odd syntax due to historical/political reasons, explained in quote later

```
class TextDocument: public Document // inherit from Document
{
public:
    //Constructor, destructor
    virtual void convertToPixelArray() const override;
    virtual int getPriority() const override;

    void setFont(const string& font); //text-specific formatting
    void setSize(int size);

private:
    //stuff here
}; //end TextDocument
```

Have implementation



```
class TextDocument: public Document
```

```
class GraphicsDocument: public Document
```

```
class PortableFormatDocument: public Document
```

```
class SpreadsheetDocument: public Document
```

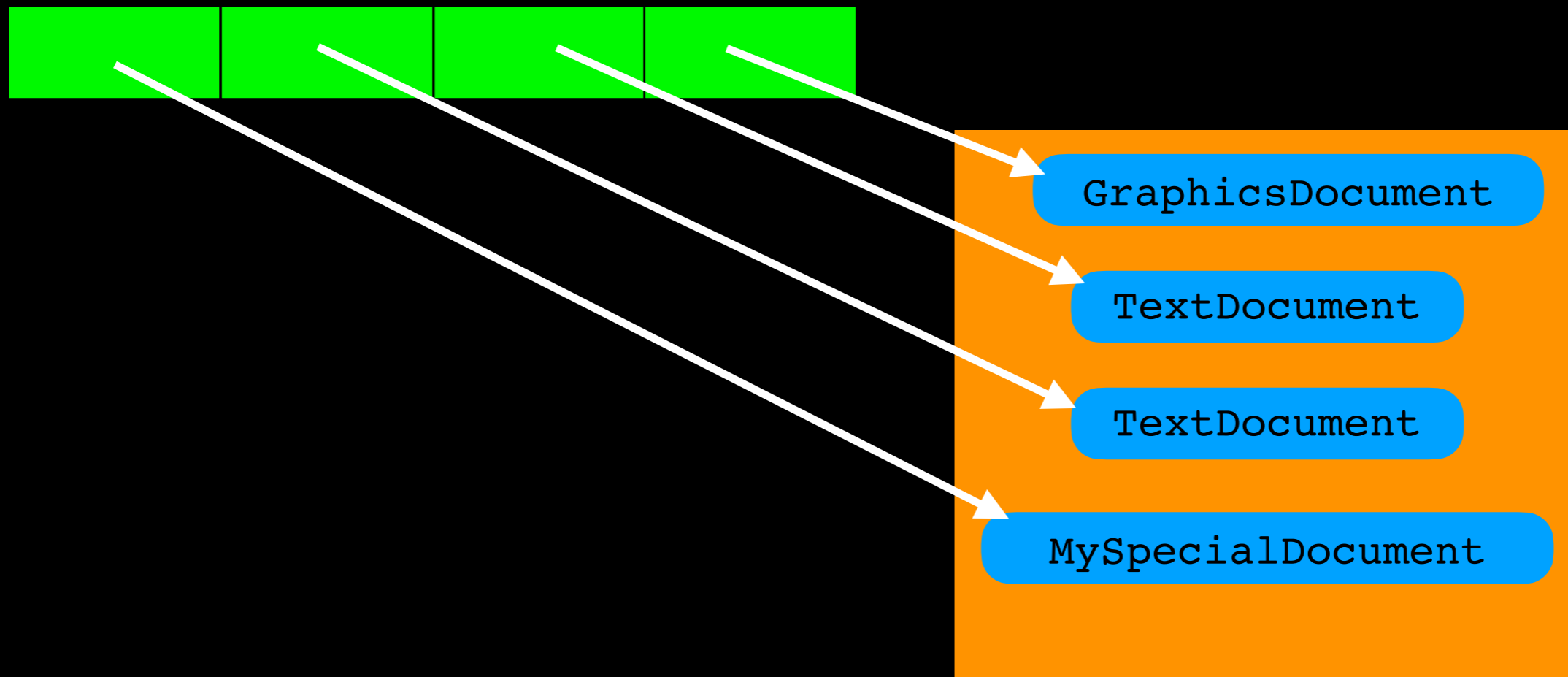

But how does compiler know whose
`convertToPixelArray()` to call?

`TextDocument::convertToPixelArray?`

`GraphicsDocument::convertToPixelArray?`

Where are we going?

I want to **store all kinds of documents** in my `BatchPrinter` queue

I want to **access** the correct `convertToPixelArray()` method specific to each different document type

main()

```
BatchPrinter myBatchPrinter;
```

```
Document* myTextDocument = new TextDocument;
```

```
Document* myGraphicsDocument = new GraphicsDocument;
```

```
//do stuff
```

```
myBatchPrinter.addDocument(myTextDocument)
```

```
myBatchPrinter.addDocument(myGraphicsDocument)
```

```
myBatchPrinter.printAllDocuments();
```

```
myTextDocument->convertToPixelArray();
```

```
myGraphicsDocument->convertToPixelArray();
```

TextDocument **is-a** Document

GraphicsDocument **is-a** Document

We can point to objects of derived class using pointers to base class

We store in printer queue pointers to Document but really can access any derived class document

convertToPixelArray is marked **virtual** so the appropriate function call is **determined at runtime**

Late Binding via Virtual Functions

Avoid statically binding function calls at compile time

Must declare functions as `virtual` for **late binding**

Polymorphism

We just saw an example of *polymorphism* (literally *many forms*)

With *virtual* functions the outcome of an operation is determined at execution time

With basic inheritance we were just saving ourselves the trouble of re-writing code

Abstract Class

Pure virtual function (=0) has no implementation

Abstract class

- Has at least one **pure virtual function**
- Cannot be instantiated because does not have implementation for some/all its member functions

```
Document myDocument; //Error! ←  
Document* myDocument = new Document; //Error! ←
```

“The curious `=0` syntax was chosen over the obvious alternative of introducing a new keyword `pure` or `abstract` because at the time I saw no chance of getting a new keyword accepted. Had I suggested `pure`, Release 2.0 would have shipped without `abstract classes`, I chose `abstract classes`. Rather than risking delay and incurring the certain fights over `pure`, I used the traditional C and C++ convention of using `0` to represent ‘not there’ ”

Bjarne Stroustrup

Recap Basic Inheritance

main()

```
Base base_object;  
Derived derived_object;
```

```
// stuff here
```

```
base_object.someMethod(); //calls Base function  
derived_object.someMethod(); // calls Derived function - Overriding!!!
```

```
Base  
someMethod();  
...
```

```
Derived: public Base  
someMethod() override;  
...
```

Recap Polymorphism

main()

```
Base* base_ptr = new Base;  
Base* derived_ptr = new Derived;  
  
// stuff here  
  
base_ptr->someMethod(); //calls Base function  
derived_ptr->someMethod(); // ???
```

```
Base  
someMethod();  
...
```

```
Derived  
someMethod() override;  
...
```

Recap Polymorphism

main()

```
Base* base_ptr = new Base;  
Base* derived_ptr = new Derived;
```

```
// stuff here
```

```
base_ptr->someMethod(); //calls Base function  
derived_ptr->someMethod(); // call Derived function - LATE BINDING!!!!
```

Base

```
virtual someMethod();  
...
```

Derived

```
someMethod() override;  
...
```

Recap Abstract Class

```
class Document:
{
public:
    //Constructor, destructor
    virtual void convertToPixelArray() const = 0;
    virtual int getPriority() const = 0;

private:
    //stuff here
}; //end Document
```

This function has no implementation**



Polymorphism without abstraction

Superclass **need not** be abstract

Virtual functions in superclass **need not** be pure
virtual

Polymorphism without Abstract Classes

```
class Skater
{
public:
    //constructor, destructor
    virtual void slowDown();
    //virtual, not pure

private:
    //stuff here
}; //end Skater
```

```
void Skater::slowDown()
{
    applyBrakes();
} //end slowDown
```

```
class InexperiencedSkater:
    public Skater
{
public:
    //constructor, destructor
    virtual void slowDown() override;
private:
    //stuff here
}; //end InexperiencedSkater
```

```
void InexperiencedSkater
    ::slowDown()
{
    fallDown();
} //end slowDown
```

implementation does not
have **virtual** or
override keyword

Polymorphism without Abstract Classes

`main()`

```
Skater* firstSkater = new Skater;  
firstSkater->slowDown();    // applyBrakes() ←  
  
Skater* secondSkater = new InexperiencedSkater;  
secondSkater->slowDown();    // fallDown() - LATE BINDING! ←
```

Polymorphism without Abstract Classes

Need not override **non-pure virtual** functions

```
class StuntSkater: public Skater
{
public:
    //constructor, destructor - note no mention of slowDown
    void frontFlip();
    void backFlip();
private:
    //stuff here
}; //end StuntSkater
```

```
// stuff here
```

```
Skater* stunt_skater = new StuntSkater;
stunt_skater->slowDown(); // applyBrakes() ←
```

Warning

```
class NotVirtual
{
public:
    void notAVirtualFunction();
}; //end NotVirtual
```

```
class NotVirtualDerived: public NotVirtual
{
public:
    void notAVirtualFunction() override;
}; //end NotVirtualDerived
```

```
NotVirtual* nv = new NotVirtualDerived;
nv->notAVirtualFunction(); // OUCH!!! calls NotVirtual's member
                           // instead of NotVirtualDerived's member
```

When using pointers to base class, to let derived classes override functions in base class **must** make the base class's function **virtual**

More design considerations

Back to Document class

Assume we realize all types of documents have **width** and **height** data members

Makes sense to move them into base class

Don't want client to have direct access to data members

```
class Document:
{
public:
    //Constructor, destructor
    virtual void convertToPixelArray() const = 0;
    virtual int getPriority() const = 0;

private:
    int width, height; //Problem!!! ←
    //stuff here
}; //end Document
```

protected Access in Base Class

```
class Document:
{
public:
    //Constructor, destructor
    virtual void convertToPixelArray() const = 0;
    virtual int getPriority() const = 0;

protected:
    int width, height;
    //stuff here

private:
    //stuff here
}; //end Document
```

Access Specifiers Base Class members

public

accessible by everyone

private

accessible within class and by friends

protected

accessible within class, by friends and by **derived
classes**

Access Specifiers for Inheritance

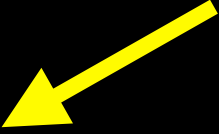

```
class Derived: public Base
{
public:
    //Stuff here

private:
    //Stuff here

}; //end Derived
```

Inheritance accessibility

Access in Base Class	Inheritance Method	Access in Derived Class
public	public <i>is-a</i>	public
protected		protected
private		no access
public	protected <i>is-implemented-and-inherited-as</i>	protected
protected		protected
private		no access
public	private <i>is-implemented-as</i>	private
protected		private
private		no access

We will not discuss the details of protected and private inheritance in this course

override specifier

Explicitly tell compiler you mean to override a function

Compiler will check!

Also self-documenting

```
class BaseClass
{
    virtual void f(int);
};

class DerivedClass: public BaseClass
{
    virtual void f(float) override; //Compile-time error
};
```



final specifier

- Prevents inheritance
- Prevents deriving classes from overriding methods

```
class A
{
    virtual void f();
};

class B : public A
{
    void f() final override; //cannot override f()
};

class C: public B final //cannot inherit from C
{
    void f() override; //Error, f is final! ←
```

```
class D: public C{} //Error C is final! ←
```

Runtime Costs of Virtual Functions

Function call overhead

- C++ maintains **virtual function tables** that store pointers to each virtual function
- Determine which function to call at execution time by looking-up **v-table** of object being pointed to

Clever! But still

Slower

Extra space for v-tables

Overhead -> mark individual functions **virtual** to take advantage of polymorphism only when appropriate

Fully polymorphic inheritance would be overkill in most cases

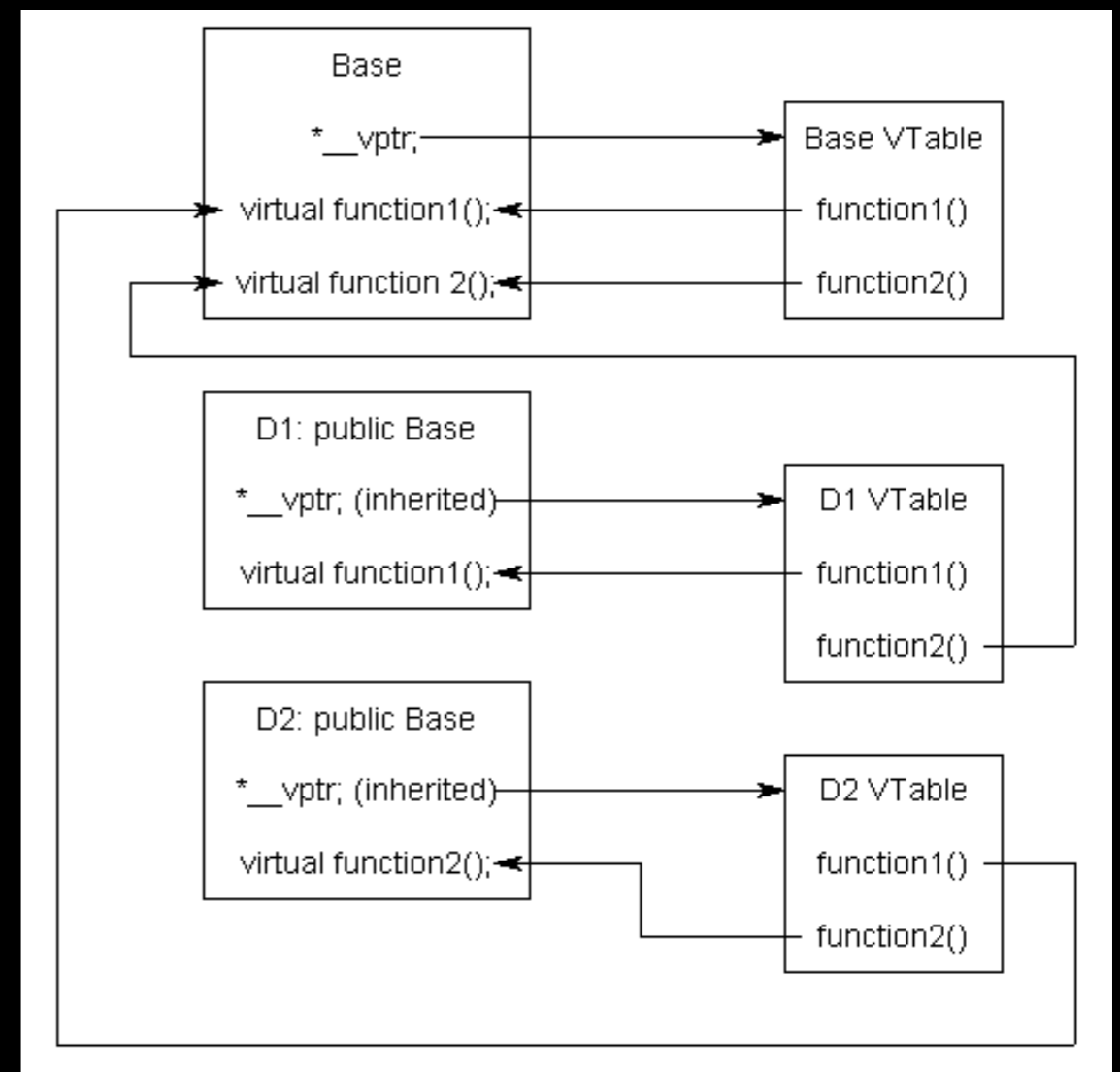

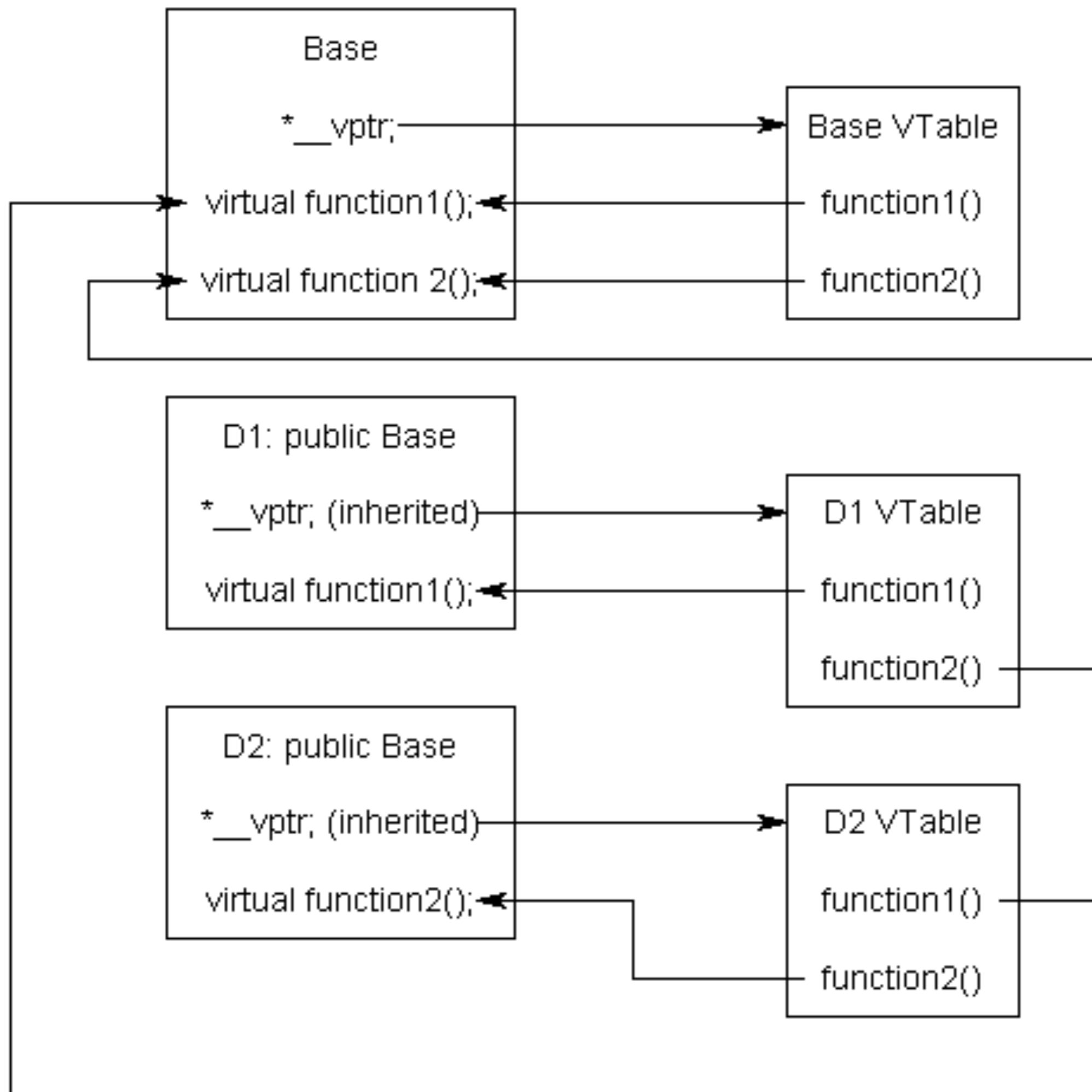

Recap

Polymorphism -> **virtual functions**

Pure vs **non-pure** virtual functions

Polymorphism with or without **abstract classes**

override and **final**

Overhead

Polymorphism Recap

Base-class pointer to Derived class

Determine behavior at runtime (**late binding**)

HOW? `virtual`

WHY? store different type of (Derived) objects in same container and retain access to each object's distinct behavior

Details

There is a lot of detail one needs to pay attention to when using Polymorphism

The following slides are for those of you who wish to dig a little deeper into the topic but will not be on exams

These are marked with 



Need to pay **extra** attention to **destructors!!!**

With **Polymorphism** destructor **MUST** always be **virtual!!!**



```
class BaseClass()  
{  
public:  
    BaseClass();  
    ~BaseClass();  
  
}; //end BaseClass
```

```
class DerivedClass:  
    public BaseClass  
{  
public:  
    DerivedClass();  
    ~DerivedClass();  
  
private:  
    char* myString;  
}; //end DerivedClass
```

```
DerivedClass::DerivedClass()  
{  
    //allocate some memory  
    myString = new char[128];  
}  
  
DerivedClass::~~DerivedClass()  
{  
    //deallocate memory  
    delete[] myString;  
}
```

```
main()
```

```
BaseClass* myClass = new DerivedClass;  
delete myClass; //PROBLEM!!! ←
```

**BaseClass destructor is invoked.
Need to allow late binding for destructor!!!**



Fix →

```
class BaseClass()
{
public:
    BaseClass();
    virtual ~BaseClass();

}; //end BaseClass

class DerivedClass:
    public BaseClass
{
public:
    DerivedClass();
    ~DerivedClass();

private:
    char* myString;
}; //end DerivedClass
```

```
DerivedClass::DerivedClass()
{
    //allocate some memory
    myString = new char[128];
}

DerivedClass::~~DerivedClass()
{
    //deallocate memory
    delete[] myString;
}
```

```
main()
BaseClass* myClass = new DerivedClass;
delete myClass; // both destructors
                //invoked
```

Problem fixed! BOTH destructors invoked



Virtual Functions in Constructors and Destructors

Recall

- **BaseClass** constructor invoked before **DerivedClass**'
- **DerivedClass** destructor invoked before **BaseClass**'

If **virtual function** in **constructor/destructor** is called polymorphically could try to access **uninitialized/deallocated** data

C++ prevents this by calling virtual functions in **constructors/destructors** **non-polymorphically**



```
class BaseClass()  
{  
public:  
    BaseClass()  
    {  
        someVirtualFunction();  
    }  
    virtual void someVirtualFunction()  
    {  
        cout << "Base" << endl;  
    }  
}; //end BaseClass
```

```
class DerivedClass: public BaseClass  
{  
public:
```

```
    virtual void someVirtualFunction()  
    {  
        cout << "Derived" << endl;  
    }  
}; //end DerivedClass
```

```
main()  
  
DerivedClass myDerivedClass;
```

Standard output:

Base





Invoking Virtual Members Non-Virtually

Sometimes may need to call the `BaseClass` version of a virtual function from a `DerivedClass`

```
void DerivedClass::someFunction()  
{  
    BaseClass::someVirtualFunction(); // no polymorphism  
    //do more stuff  
}
```

Copy Constructors and Assignment



Operators with Inheritance

Can become complicated beasts with inheritance!!!

Must **always call explicitly** BaseClass within
DerivedClass



```
class Base()
{
public:
    Base();
    Base(const Base& other);
    Base& operator=(const Base& other);
    virtual ~Base();
    //other public and protected members here that will be inherited

}; //end BaseClass
```

```
class Derived: public Base
{
public:
    Derived();
    Derived(const Derived& other);
    Derived& operator=(const Derived& other);
    virtual ~Derived();
private:
    char* theString; //a C string
    //generic helper functions
    void copyOther(const Derived& other);
    void clear();
}; //end DerivedClass
```

Derived Implementation



```
//generic "copy other" private member function
void Derived::copyOther(const Derived& other)
{
    theString = new char[strlen(other.theString)+1];
    strcpy(theString, other.theString);
}

// clear out private member function
void Derived::clear()
{
    delete[] theString; //deallocate memory
    theString = NULL;   //avoid dangling pointer
}
```

Derived Incorrect Implementation



```
//copy constructor
Derived::Derived(const Derived& other)
{
    copyOther(other);
}

//assignment operator
Derived& Derived::operator=(const Derived& other)
{
    if(this != other)
    {
        clear();
        copyOther(other);
    }
    return *this;
}
```

Derived Incorrect Implementation



```
//copy constructor
Derived::Derived(const Derived& other)
{
    copyOther(other); //WRONG!!!
}

//assignment operator
Derived& Derived::operator=(const Derived& other)
{
    if(this != other)
    {
        clear();
        copyOther(other); //WRONG!!!
    }
    return *this;
}
```



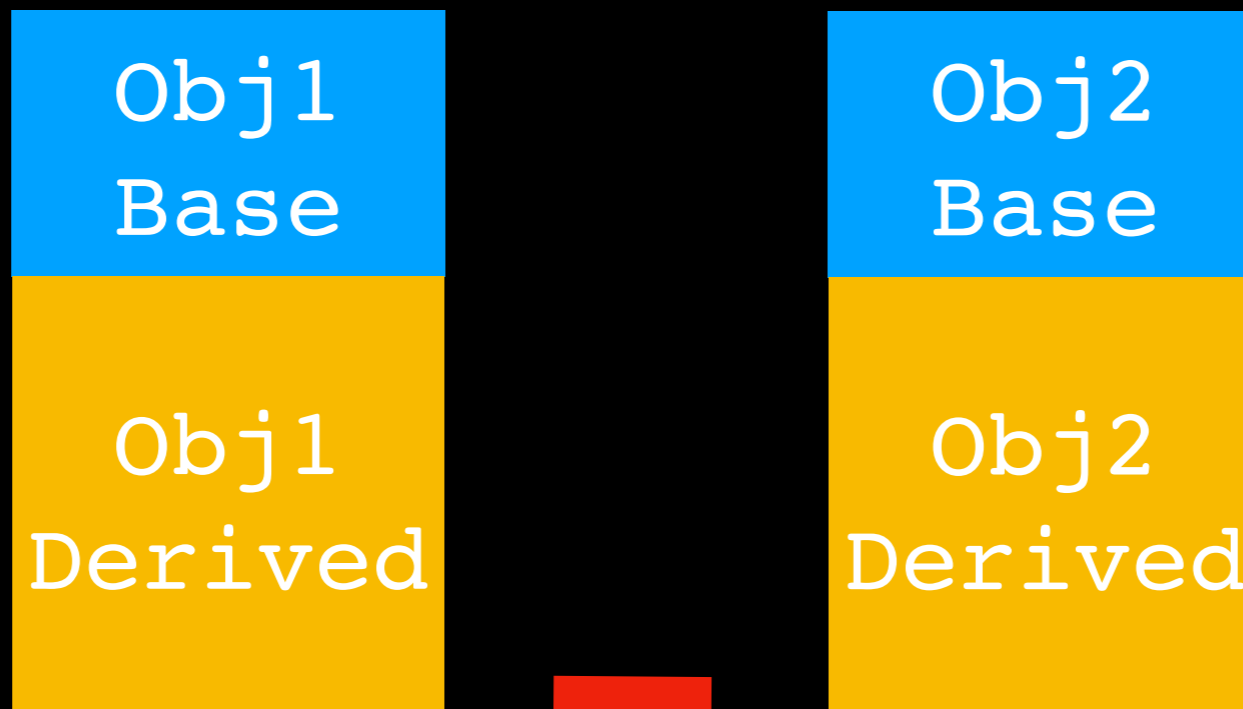

After invoking copy constructor
or assignment operator

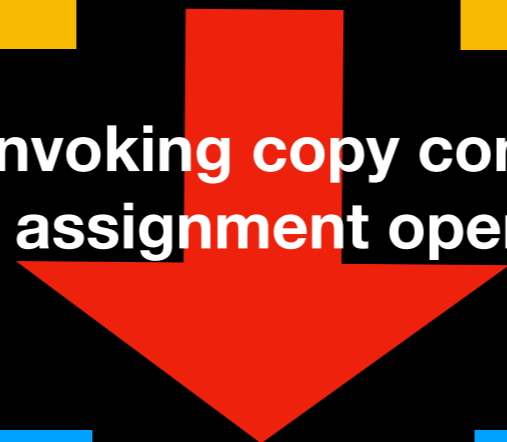

PROBLEM!!!

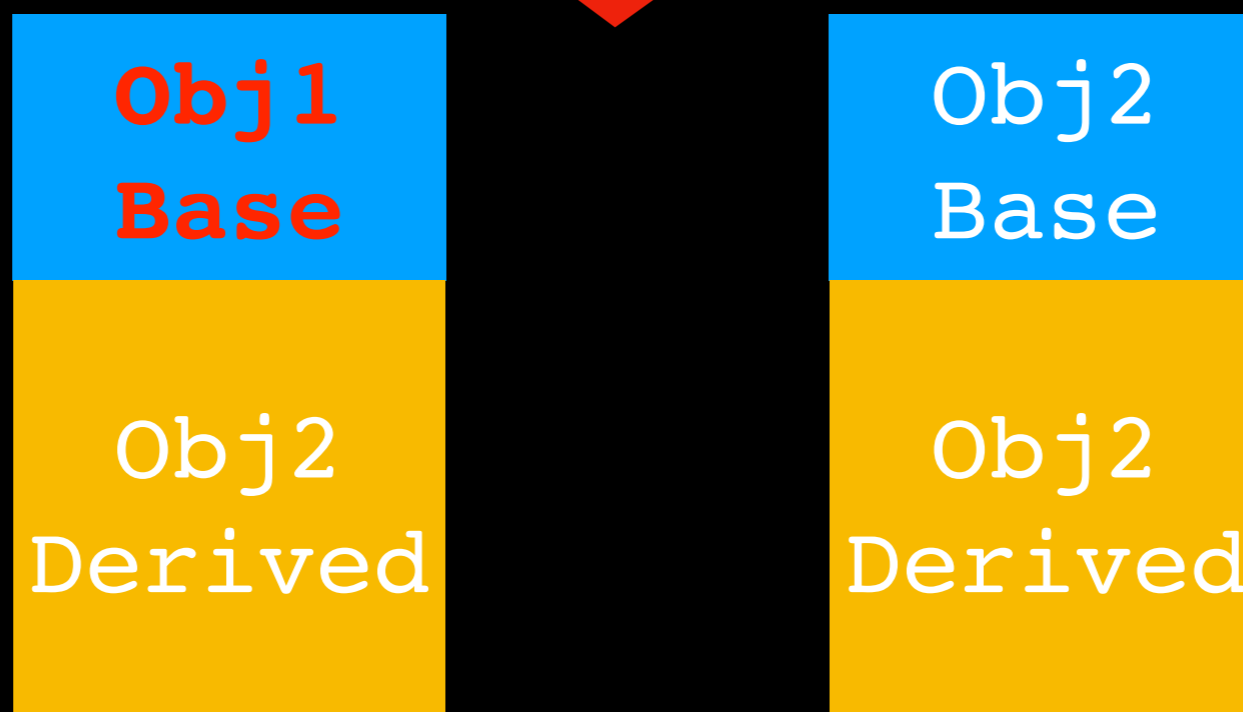

Derived Correct Implementation



```
//copy constructor
Derived::Derived(const Derived& other): Base(other) //CORRECT!!!
{
    copyOther(other);
}

//assignment operator
Derived& Derived::operator=(const Derived& other)
{
    if(this != other)
    {
        clear();
        Base::operator=(other); //CORRECT!!! Invoke Base operator=
                                //explicitly
        copyOther(other);
    }
    return *this;
}
```

Slicing



Copy ONLY BaseClass portion of object

Opposite of previous case

```
Base* ptr1;  
Base* ptr2 = new Derived; // pointer of type Base that points to type Derived  
  
//do stuff  
  
*ptr1 = *ptr2; //copy value pointed to by ptr2 into variable pointed to by  
              //ptr1
```

Note potential problem!!!

The above expands into

```
ptr1->operator= (*ptr2);
```

Invoking the `operator=` of the Base **loosing** all data of `Derived` portion

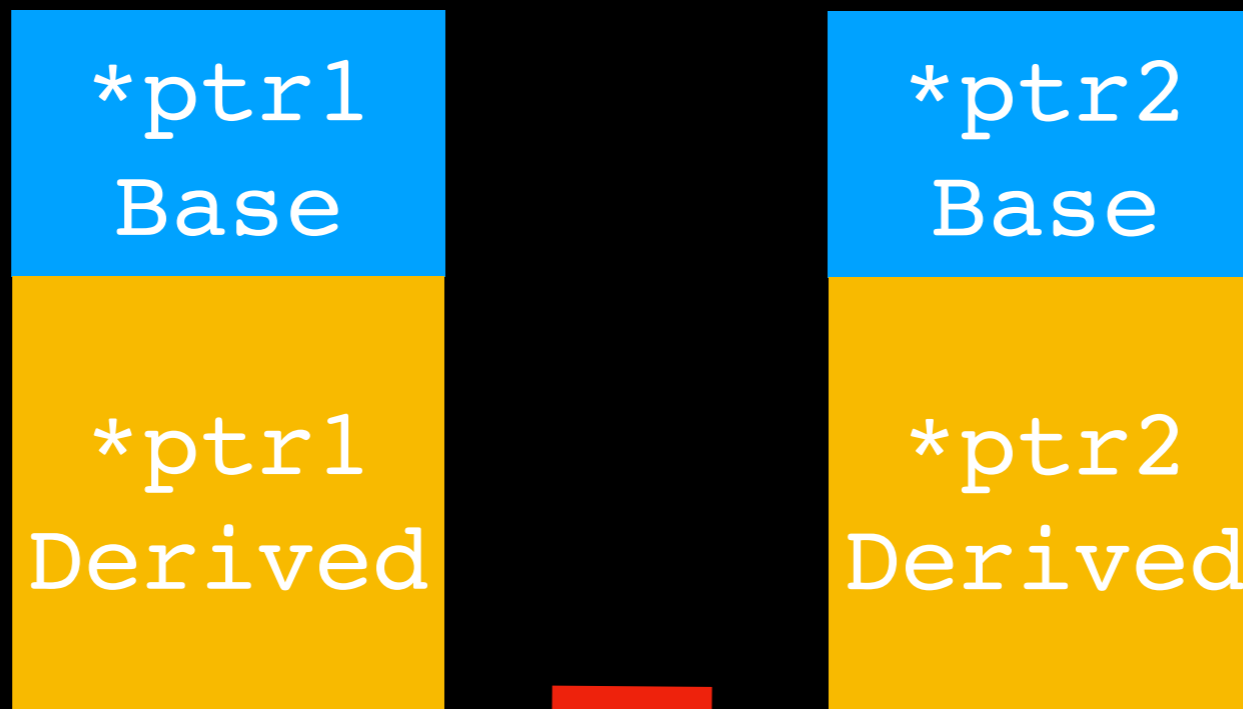

***ptr1 = *ptr2**

PROBLEM!!! →



Slicing via Copy Constructor



```
void doSomething(Base baseObject)
{
    //do something
}
```

```
Derived myDerived;
doSomething(myDerived);
```

PROBLEM!!! Parameter baseObject will be initialized using Base copy constructor

Slicing

Ever more insidiously!!!



```
vector<Base> myBaseVector;  
Base* myBasePtr = someFunction(); //pointer to Base  
//ATTENTION myBasePtr could point to Derived object  
myBaseVector.push_back(*myBasePtr);
```

If `someFunction` returns a pointer to an object of type **Derived** calling `push_back` on object of type **Derived** will likely **slice** the object storing only its **Base** data

Possible solution: store pointers in `myBaseVector` instead of objects

Casting



Forcing one datatype to be converted into another

Up-casting (Derived to Base) automatically available through inheritance

```
Base* basePtr;  
Derived* derivedPtr;  
//do stuff  
basePtr = derivedPtr; //automatic conversion Derived is-a Base
```

Down-casting (Base to Derived)

```
Base* basePtr = new Derived; // pointer of type Base points to  
Derived  
//do stuff  
Derived* derivedPtr = (Derived*) basePtr;
```

Casting



Classic C++ cast too powerful => no checks.
Could write something totally nonsensical

```
Base* basePtr;  
vector<double>* myVectorPtr = (vector<double>*) basePtr;  
//PROBLEM!! Makes no sense, BUT no compiler error
```

```
const Base* basePtr = new Derived;  
// do stuff  
Derived* derivedPtr = (Derived*) basePtr;  
//PROBLEM!!! Lost constness of Base object  
//derivedPtr is now free to modify it
```

static_cast



static_cast checks at compile time that cast "makes sense"

Allows:

- Converting between **primitive types** (e.g. `int` to `float`)
- Converting pointers or references of `Derived` type to pointers or references of `Base` type (e.g. `Derived*` to `Base*`) where target is at least as **const** as the source
- Converting pointers or references of `Base` type to pointers or references of `Derived` type (e.g. `Base*` to `Derived*`) where target is at least as **const** as the source

```
Base* basePtr = new Derived;  
// do stuff  
Derived* derivedPtr = static_cast<Derived*>(basePtr);
```

dynamic_cast



If **Base*** did not point to **Derived** object, **static_cast** would succeed

=> runtime problems

e.g. access **Derived** data members not present in **Base**

```
Base* basePtr = new Base;  
Derived* derivedPtr1 = (Derived*)basePtr; //BAD!!!  
Derived* derivedPtr2 = static_cast<Derived*>(basePtr); //BAD!!!  
Derived* derivedPtr3 = dynamic_cast<Derived*>(basePtr); //GOOD!!!
```

Will return a NULL pointer

Conclusion

Polymorphism is easy, Just put **virtual** everywhere and the compiler will take care of the rest!

Conclusion

Polymorphism is easy, Just put **virtual** everywhere and the compiler will take care of the rest!



Real Conclusion

Overhead! Use it only when useful/necessary

Carefully craft **constructors**

Always make **destructor virtual**

Beware of **Slicing** (in all its forms)

Beware of **casting** and use level most appropriate and safe for your situation